

# **EVALUATION OF THE BIGMOW AUTOMATIC MOWER**

*For*

**BELROBOTICS S.A  
Avenue Lavoisier  
16b – B – 1300 Wavre**

*By*

**M Ferguson and AJ Newell**

**STRI, St Ives Estate, Bingley, BD16 1AU.  
[Mark.ferguson@stri.org.uk](mailto:Mark.ferguson@stri.org.uk)**

**Project No. TB101281**

**November 2010**

**CONFIDENTIAL****MF/TB101281  
November 2010****EVALUATION OF THE BIGMOW AUTOMATIC MOWER****SUMMARY**

Trial work to evaluate the Bigmow automatic lawnmower was conducted at STRI throughout the spring, summer and autumn of 2010. Bigmow was compared with a traditional cylinder mower of the type used to mow football pitches. Assessments such as visual turf quality and colour, live ground cover, cleanness and evenness of cut and weed content were made throughout the trial period. Bigmow compared favourably with the cylinder mower in terms of overall turf quality. In terms of labour time, Bigmow required significantly less labour time than the cylinder mower. Our conclusion was that Bigmow is an effective alternative to a cylinder mower when cutting large areas of amenity turf at cutting heights of twenty five millimetres or above.

**INTRODUCTION**

The Bigmow is an automatic lawnmower developed by Belrobotics S.A. It is designed to maintain large areas of amenity turf. It is electrically operated via a rechargeable battery and requires no supervision. It can be set to mow as frequently as necessary mulching the clippings into fine particles and returning them to the turf.

**MATERIALS AND METHODS**

In the spring of 2010 a trial to evaluate the Bigmow automatic lawnmower was set up at the STRI. The trial compared Bigmow and a traditional cylinder mower, typical of the type used to mow football pitches. The trial began in March 2010 and was completed in November 2010. To compare mowers two large plots 10 x 25 m were laid out, one for Bigmow to mow and one to be mown by the cylinder mower. Twenty 2 m x 2 m assessment positions were measured out in each area. Assessments of turf quality were carried out prior to the start of the trial (March assessments) and subsequently on a monthly basis throughout the trial period.

**Assessments***Turf Quality*

Turf quality was assessed by subjective visual assessment using a 1-10 scale. Assessments were made monthly (SOP no. 1B0703).

*Live Ground Cover*

Assessments of live ground cover were made prior to the start of the trial and at the end of the trial period. Assessments were made using the optical point quadrat method (SOP no 1B1199). In addition to this measurements of chlorophyll index were made on a monthly basis using a 'Fieldscout' CM100 Chlorophyll meter (Spectrum Technologies, Inc).

*Cleanness of Cut*

Cleanness of cut was assessed on a monthly basis (SOP no 301398).

***Evenness of Cut***

The evenness of cut was also assessed on a regular basis throughout the trial period. This was a subjective visual assessment (1 – 9) designed to estimate if all the grass in an assessment area had been mown at the same height. Lower scores were given if grass had been laid flat and had subsequently left a tuft of unmown grass.

***Broad-Leaved Weeds***

The content of broad-leaved weeds in each position was also assessed on a 1 – 9 scale (1= no weeds; 9 = full cover of weeds). This assessment was conducted four times during the trial period.

***Surface Hardness***

Measurements of surface hardness were made prior to the start of the trial and at the end of the trial period using a clegg impact soil tester (SOP no 200698).

***Visual Colour***

Turf colour was assessed by subjective visual assessment using a 1 – 10 scale. Assessments were made monthly (SOP no 1B0803).

***Disease***

Type and severity of disease was assessed as it occurred. (SOP no 301098).

***Time Recording***

A record of all time spent setting up and maintaining each area was kept.

**RESULTS AND DISCUSSION**

The results of the trial work are presented in Tables 1 – 9. The trial itself was laid out to allow variation between mowers to be investigated using an unpaired ‘T’ test. To do this two main plots were laid out, one for Bigmow and one for the cylinder mower. Each plot contained twenty assessment positions. An average for these twenty positions for each assessment is presented in the tables along with the probability that variation between areas was significantly different. When the data was analysed we set a ninety five percent level of confidence for establishing significant differences between the two areas. This is shown in the tables as significant (S) or not significant (N.S).

Table 1 presents results for the visual turf quality assessments from March through to November. The visual quality of the turf improved throughout the spring and summer months to a peak in July for both trial plots. After this date the turf quality declined slightly but remained at a good level for the remainder of the trial period. Looking at the trial period as a whole there was very little difference between the mowers in terms of visual turf quality. There were two assessments that were significant, in May the cylinder mower scored higher and in August the Bigmow plot was significantly better. These assessments represent fluctuations that could be caused by a combination of factors such as prevailing weather conditions or mowing frequency. There were no trends to report in terms of visual turf quality, the two plots both showed an initial improvement and levelled out at an acceptable level of turf quality.

TABLE 1  
Visual turf quality scores (1 = poor; 9 = excellent)

	Mean		
	Bigmow	Cylinder Mower	Probability
March	5.3	5.0	<i>N.S</i>
April	5.5	5.3	<i>N.S</i>
May	5.7	7.2	<i>S</i>
June	7.0	6.9	<i>N.S</i>
July	7.2	7.3	<i>N.S</i>
August	7.1	6.5	<i>S</i>
September	6.5	6.3	<i>N.S</i>
November	6.7	6.5	<i>N.S</i>

The results for the visual turf colour assessments are presented in Table 2. The general trend here is that the cylinder mower plot was greener for longer periods of the trial. This would indicate that the ‘fertiliser effect’ of the returned clippings ‘greened up’ this plot more than the mulched clippings ‘greened up’ the Bigmow plot. This trend was reversed in June when the Bigmow plot had significantly higher colour scores. This assessment followed a prolonged period of dry weather. It is possible that the cylinder mower plot suffered more in the dry conditions. However, we cannot prove this was the case. Later in the summer there was very little difference between mowing areas until the final two assessments which showed the cylinder mower plot to have significantly higher (darker green) colour scores. It is worth noting that the Bigmow plot, despite generally having lower colour scores than the cylinder mower, improved in colour throughout the spring to a peak in June and subsequently retained good colour for the remainder of the trial period.

TABLE 2  
Visual turf colour scores (1 = light green; 9 = dark green)

	Mean		
	Bigmow	Cylinder Mower	Probability
March	4.8	5.1	<i>N.S</i>
April	5.4	8.2	<i>S</i>
May	6.0	7.5	<i>S</i>
June	8.0	5.6	<i>S</i>
July	6.8	7.0	<i>N.S</i>
August	7.1	6.7	<i>N.S</i>
September	6.6	7.9	<i>S</i>
November	7.0	7.7	<i>S</i>

Table 3 presents results for the live ground cover measurements. This assessment was conducted at the start and finish of the trial period. The results were not significant in favour of either mower. It is worth noting, however, that live ground cover increased hugely in both trial plots. This indicates that regular mowing with either mower throughout the growing season increased the density of the sward.

TABLE 3  
Live ground cover results (%)

	Mean		
	Bigmow	Cylinder Mower	Probability
March	58.8	58.1	<i>N.S</i>
November	86.0	87.0	<i>N.S</i>

Results for the Chlorophyll Index measurements are presented in Table 4. The chlorophyll index measurements effectively give us an estimation of live ground cover and to some extent 'greenness'. To a large degree these results mirror those recorded for visual turf colour. The general trend was for the cylinder mower to have slightly higher values, significantly so in most cases, with a reversal of this trend in June. The summer months of July and August see the two areas level out with a return to higher values for the cylinder mower towards the end of the trial period. Although the cylinder mower plot had generally higher values it is again worth noting that the results for the Bigmow plot show a steady increase in chlorophyll index throughout the trial period.

TABLE 4  
Chlorophyll index measurements (relative live ground cover)

	Mean		
	Bigmow	Cylinder Mower	Probability
March	227.0	229.9	N.S
April	231.7	369.3	S
May	292.4	308.7	S
June	219.5	133.7	S
July	246.6	241.4	N.S
August	273.7	275.5	N.S
October	299.2	350.8	S
November	325.9	366.5	S

Surface hardness measurements were taken at the start and end of the trial period. The results are presented in Table 5. The pre-treatment results show that the Bigmow plot was slightly firmer at the start of the trial process. By the end of the trial period the Bigmow plot was significantly firmer than the cylinder mower plot. The most plausible explanation (though not proven) for this difference is that the cylinder mower returned large amounts of clippings to the plot on a weekly basis which failed to break down and thus increased the thatch layer at the base of the sward. Bigmow cuts more frequently, returning small amounts of clippings to the plot on a regular basis which should break down quicker.

TABLE 5  
Surface hardness measurements (gravities)

	Mean		
	Bigmow	Cylinder Mower	Probability
March	55.6	53.5	S
November	68.3	58.4	S

Only one incidence of turf disease was recorded during the trial period. The results for this assessment are presented in Table 6. These show that the turf disease (red thread – *Laetisaria fuciformis*) was significantly more severe in the cylinder mower plot. It is difficult to read too much into these data as there was only one set.

TABLE 6  
Turf disease scores

	Mean		
	Bigmow	Cylinder Mower	Probability
September	1.2	2.1	S

Table 7 presents the scores for cleanness of cut. This assessment looks at individual blades of grass within assessment areas to identify if they have been cut cleanly by the mower or if the mower has left a ragged edge on the leaf. The Bigmow plot was initially cutting significantly more cleanly than the cylinder mower. This could be due to the fact that Bigmow was removing small amounts of clippings on a regular basis and the cylinder mower had to cope with removing a relatively large amount of herbage on a weekly basis. However as the trial progressed these scores levelled out and both mowers achieved good scores for cleanness of cut. As the trial progressed it is likely that growth slowed down and the cylinder mower was able to cope better with the amount of herbage it was being asked to remove.

TABLE 7  
Cleanness of cut scores (1 = poor; 9 = excellent)

	Mean		
	Bigmow	Cylinder Mower	Probability
March	5.1	5.0	N.S
April	7.0	5.9	S
June	8.0	5.5	S
July	7.9	7.8	N.S
August	7.4	7.6	N.S
September	8.0	8.0	N.S
November	7.9	7.9	N.S

Results for evenness of cut are presented in Table 8. This assessment was included when it became apparent that the cylinder mower had a tendency to lay the grass flat with the front roller and subsequently not cut everything if the grass was too long to spring back into an upright position. The results for this assessment highlight one of Bigmow's principle strengths. Regular mowing with Bigmow ensured that the sward in the Bigmow plot remained at a very even height. The cylinder mower plot was acceptable in terms of evenness, but tended to have small tufts where the grass had not been cut evenly. The results in this section strongly favour the Bigmow area which was consistently more evenly cut than the cylinder mower area.

TABLE 8  
Evenness of cut scores (1 = poor; 9 = excellent)

	Mean		
	Bigmow	Cylinder Mower	Probability
April	7.7	3.8	S
July	8.0	6.4	S
August	8.0	4.9	S
September	8.0	6.0	S
November	8.0	6.3	S

It became apparent as the trial work moved into summer that broad-leaved weeds were beginning to invade the trial plots. From July onwards regular assessments of the weed population were conducted. The results for these assessments are presented in Table 9. These show that there was a significant difference in weed content between the Bigmow area and the cylinder mower area in favour of the Bigmow area. It would

appear that the difference was caused by the mower treatments since the trial plots were maintained in exactly the same way but for the mowing. A possible explanation is that because Bigmow mowed the turf more often the weeds had less chance to develop because many weeds are not tolerant of regular mowing. The ability to spread weeds probably differed between mowers with the cylinder mower throwing clippings over a wider area.

TABLE 9  
Broad-leaved weed population scores (1 = none; 9 = total infestation)

	Mean		Probability
	Bigmow	Cylinder Mower	
July	1.6	3.6	S
August	1.9	3.7	S
September	2.6	5.3	S
November	2.9	4.7	S

The final aspect of the trial work dealt with labour time. We can conclusively state that the trial work found that Bigmow used substantially less labour time than the cylinder mower. Cutting weekly or twice weekly from March to November the cylinder mower cut the trial area forty two times, each operation (including setting up the mower) took approximately twenty minutes, giving a total labour time of fourteen hours. In comparison with this installing Bigmow takes two men approximately two hours. Once this is done and Bigmow is programmed the turf manager just needs to ensure that the operating area is free of debris on a regular basis. This represented a five minute weekly task. Re-programming Bigmow is also a quick job, in our trial Bigmow was re-programmed three times; each programming took no more than five minutes. In total, the labour time spent on the Bigmow plot was less than eight hours. A considerable labour saving compared with the cylinder mower.

When these figures are scaled up the labour saving becomes more significant. We estimate that mowing a football pitch (with a pedestrian 34" cylinder mower) and returning the clippings would take two to two and a half hours. If the clippings were removed this figure would be closer to three hours depending on growth. The labour time for Bigmow remains the same as that recorded in our trial. The only adjustments to this time would be for removing debris from the sward. In a stadium environment this would perhaps not be necessary at all. However, on public playing fields debris removal would be an important part of the process, putting a time on this task is difficult as it would vary greatly from week to week. However, it is our view that the debris that you would need to remove for Bigmow to function effectively would also need to be removed for a conventional mower to function effectively. Based on these figures the Bigmow will save a considerable amount of labour time.

## **CONCLUSION**

In conclusion Bigmow compared favourably with the cylinder mower. Overall there was very little to choose between the two mowers in performance terms. Visual turf quality scores throughout the trial period were generally similar. The cylinder mower plot received higher visual colour scores and the measurements of chlorophyll index were also higher. The Bigmow plot was significantly better in terms of the overall evenness of the cut, whereas cleanness of cut for both plots was very similar once the trial was established (Bigmow scored higher for cleanness of cut initially). In terms of weed content the cylinder mower plot had a much higher ingress of broad-leaved

weeds. This observation warrants further investigation. Weeds can seriously affect the appearance of turf generally and playing quality of sports turf. Control of weeds costs time and money. If reducing weed ingress was a proven benefit for Bigmow this would be a major additional benefit over a conventional mower.

The trial work confirms that Bigmow is an effective alternative to a traditional cylinder mower at a cutting height of twenty five millimetres where clippings are returned. Bigmow is a suitable mower to use on large areas of amenity turf such as sportsfields, parks and other amenity turf areas. Where this is done it is predicted that there could be large savings in labour.

### **QUALITY STATEMENT**

I confirm that this report is a true representation of the original data collected and that the Standard Operating Procedures referred to in the STRI Manual of Standard Operating Procedures, and those relevant to data collection, data preparation, archiving of data and preparation of reports have been implemented in full.

Prepared by: M Ferguson Date: 17 November 2010

Checked by: A J Newell Date: 19 November 2010

Final version  
checked and reviewed by: A J Newell Date: 23 November 2010

**APPENDIX 2**  
**STANDARD OPERATING PROCEDURES**

**STANDARD OPERATING PROCEDURE NO. 1B0703 (1 page)**

**VISUAL ASSESSMENT OF TURF QUALITY**

**[1] Scope**

This standard operating procedure specifies methods for assessing the visual quality of sports and amenity turf.

**[2] Principle**

Turf quality is determined by subjective visual assessment using a 1 to 10 scale. Factors taken into account are sward density, uniformity, turf colour, grass cover, weed content and disease and pest invasion.

**[3] Procedure**

One of two assessment methods shall be used depending on whether there is a need to define the overall quality and acceptability of turf or whether it is desirable to score visual differences which are apparent among treatments but are not necessarily linked to one particular use.

*(a) Assessment to define the quality and acceptability of turf*

The turf is assessed on a 1 to 10 visual scale where a score of 1 represents very poor turf quality and a score of 10 signifies very good turf quality. A value of 5 represents turf that is just acceptable and values below 5 shall be used if turf quality is not considered acceptable.

*(b) Subjective assessment of observed variations among grass cultivars, species and mixtures*

Individual plots will be assessed on a 1 to 10 scale (1 = very poor, 10 = very good). For each assessment a score of 5 will be used to describe plots which could be placed in the middle of the ranking order for that particular assessment. Scores below 5 should be given to plots which fall below this average and above 5 for those which are observed to have greater visual appeal. For each assessment the maximum range between 1 and 10 which can be reasonably scored should be used.

Two or more observers shall be used, except under unusual circumstances (e.g. external visits with only one observer present) or with written approval by the relevant head of division.

Each sampling area is assessed once by each assessor on each occasion. Where two or more individuals are carrying out the assessment, each should obtain a unique score by acting independently.

**[4] Expression of results**

Where two or more individuals carry out assessment, the mean turf quality value is calculated for each test area.

**NOTE:**

*This is a copy based on an electronic format for inclusion in reports and study plans.*

*The definitive and signed copy can be viewed at the STRI.*

## **DETERMINATION OF GROUND COVER**

### **FOREWORD**

This standard operating procedure is based upon a draft European Standard in preparation by Technical Committee CEN/217, Surfaces for sports areas.

### **[1] Scope**

This standard operating procedure specifies three methods of test for the determination of ground cover of natural turf.

### **[2] Terms and Definitions**

The proportion of ground cover occupied by the perpendicular projection of live grass material above it.

### **[3] Principle**

Three methods of test are given. Method A is a visual subjective assessment of ground cover using no measuring device. Method B uses a sampling grid to give a more systematic assessment of ground cover. Method C uses a point quadrat for when objective data are required or where a detailed assessment of species composition is needed.

In all three methods, an observer assesses the proportion of ground cover including:

- a) live grass, (this includes healthy (green) and senescent (yellow) leaf tissue together with the living stem material, which can be a variety of colours depending on the grass species).
- b) weeds;
- c) moss;
- d) dead matter and bare ground;

The procedure can be used to measure the live grass ground cover and/or ground cover for individual plant species.

### **[4] Procedure**

Ensure that the sward height is within the range appropriate for the given sport.

**Note:** The amount of cover which is recorded is dependent on the length of grass. If the sward height is higher than the value for the given sport, mow the turf before assessment. On longer turf and if the grass blades are lying in a procumbent position because of mowing or rolling, brush the test area to achieve a more usual upright position for the grass blades. If the sward height is lower than the value for the given sport, do not proceed with the determination.

#### **[4.1 Method A. Visual assessment of ground cover**

##### **4.1.1 Procedure**

With the observer standing upright directly adjacent to the test area, estimate by eye the proportion of sports surface occupied by living plant tissue, dead matter and the bare ground and

if required, the proportion covered by particular plant species. Record only living plant tissue as ground cover. Record dead matter and bare ground separately, if required. Estimate the cover visible by the upright observer. Disregard overlap of living plant tissue, i.e. do not multiple count.

**Note:** An area quadrat (similar to that described in Method B (below), but not necessarily many subdivisions), may be used to define the sampling area.

Unless otherwise specified, assess at least five randomly chosen sampling test areas on sports surfaces of less than 100 m<sup>2</sup>, assess 5–10 test areas as appropriate on sports surfaces of 100 m<sup>2</sup> to 1000 m<sup>2</sup> and assess 10-15 test areas on sports surfaces of 1000 m<sup>2</sup> to 5000 m<sup>2</sup>. Subdivide larger sports areas and test each as above.

**4.1.2 Expression of results**

Express the results as the estimated percentages of live grass tissue and, if required, give the estimated ground cover for individual plant species.

**4.2 Method B. Assessment of ground cover by frame quadrat**

**4.2.1 Apparatus**

Frame between 0.75 m x 0.75 m and 1.0 m x 1.0 m internal dimensions divided into 100 smaller squares (each subdivision representing 1% of the total area) using string, cord or thin wire as shown in Fig. 1.

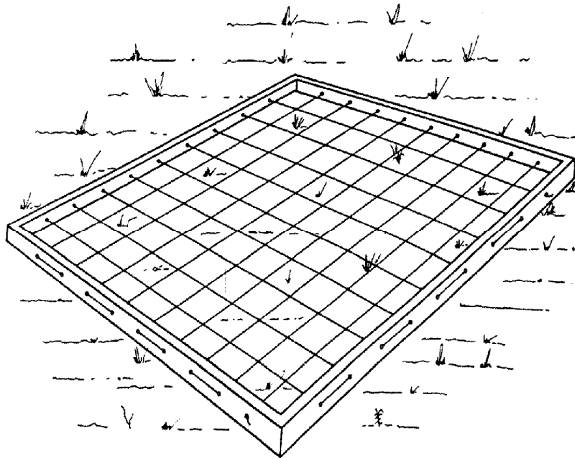

FIGURE 1. Frame for estimating ground cover.

**4.2.2 Procedure**

Depending on whether the cover components to be counted are smaller or larger than the frame subdivisions, refer to 4.2.2.1 or 4.2.2.2. With the observer standing upright, directly adjacent to the test area, estimate by eye the proportion of sports surface occupied by living plant tissue, dead matter and bare ground. Estimate the percentage of small weed plants or scattered spots of bare ground by the method described in 4.2.2.1. Assess the general distribution of plant cover as

compared with extensive bare areas or the areas occupy by large weeds, moss patches, etc. as described in 4.2.2.2.

#### ***4.2.2.1 Cover components less than subdivision size***

Estimate how many components would be required to fill a subdivision (1% of the frame), then count the number of cover components in the whole area being examined (making due estimation for any overlap which occurs) and from that, calculate the total percentage within the frame.

#### ***4.2.2.2 Cover components of subdivision size or larger***

Count how many subdivisions in the frame are wholly or more than half filled by the component being assessed. All subdivisions less than half-filled are ignored as 'empty'. With 100 subdivisions the 'full' and 'empty' subdivisions are assumed to balance out with adequate accuracy, so that 'full' subdivisions can be used as a basis for the required percentage figure.

#### ***4.2.2.3 Number of frame placings***

Unless otherwise specified, make at least five random placings of the frame on areas of less than 100 m<sup>2</sup>, take 5–10 placings as appropriate on areas of 100 m<sup>2</sup> to 1000 m<sup>2</sup> and take 10-15 placings at random for areas of 1000 m<sup>2</sup> to 5000 m<sup>2</sup>. Large areas should be subdivided into two or more areas for testing.

#### ***4.2.2.4 Expression of results***

Express the results as the estimated percentages of total live grass tissue and, if required, give the estimated ground cover for individual plant species.

### **4.3 Method C. Assessment of ground cover by point quadrat**

#### ***4.3.1 Apparatus***

**Optical point quadrat (see Figure 2).** The apparatus consists of a horizontal frame with two rows each of 10 steel pins fixed 50 mm apart within rows and 20 mm between rows.

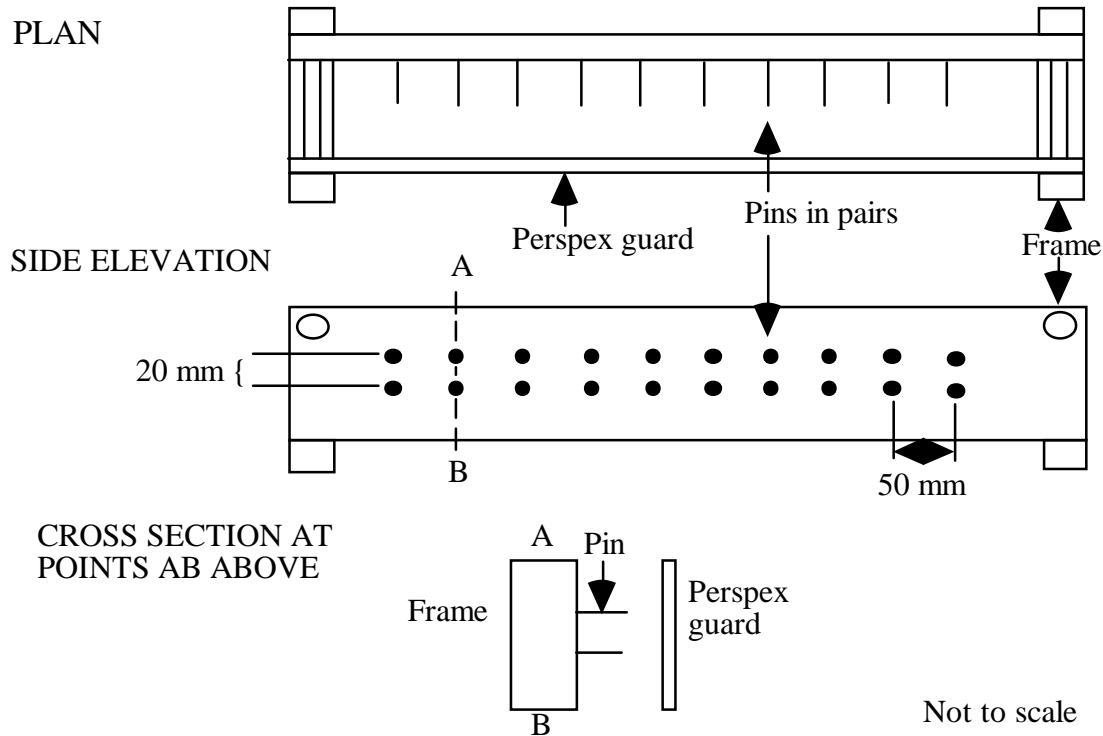

FIGURE 2. Optical point quadrat for ground cover measurement.

#### 4.3.2 Procedure

Lay the frame on the turf and ensure that the bottom row of pins is at least 10 mm above the uppermost grass blades, using supports if necessary to raise the frame. Align by eye the tips of each pair of pins to identify the point to be sampled. At each point record what is directly beneath the tips, i.e. species of grass, weed, dead matter or bare ground. Continue until the frame is completed.

Unless otherwise specified, record information from 30 randomly placed frames on areas less than 100 m<sup>2</sup>, 30–70 frames as appropriate on areas of 100 m<sup>2</sup> to 1000 m<sup>2</sup> and 70–100 frames for areas of 1000 m<sup>2</sup> to 5000 m<sup>2</sup>. Large areas should be subdivided into two or more areas for testing.

#### 4.3.3 Expression of results

Express the results as the measured percentages of total live grass tissue. The individual percentage of each grass species (live material only), weed, moss, dead matter and bare ground shall also be given, if required.

**STANDARD OF OPERATING PROCEDURE NO. 301098 (1 page)****DISEASE ASSESSMENT****[1] Scope**

This standard operating procedure describes the methods used for disease assessments on cultivar evaluation trials.

**[2] Procedure**

Severity of disease is scored differently depending on the type of disease. Diseases are classified as either patch type (e.g. red thread, dollar spot, fusarium) or diffuse type (e.g. mildew, rusts and leaf spots).

For patch type diseases a standardised subjective scoring system may be used. In this system the area affected is estimated by comparing each plot with a series of disease score cards which have a known area shaded. This system scores plots on a 0 to 13 scale (0=no disease, 1=0.02%, 2=0.05%, 3=0.10%, 4=0.50%, 5=1.0%, 6=3.0%, 7=5.0%, 8=10%, 9=20%, 10=40%, 11=60%, 12=80% and 13=100% of the plot affected). Half scores are used where the severity of the disease appears to lie between two scores.

The occurrence of patch type diseases, particularly seedling diseases, may also be scored using a frame quadrat which has been divided into 100 equal sub-divisions. To do this the quadrat is laid on each of the plots to be assessed and the number of sub-divisions which contain any disease counted.

If patch type diseases were found in more than 70% of the 100 sub divisions in a number of plots in the assessment the severity of disease may be estimated differently. In such cases a subset of 20 sub-divisions per quadrat would be used with disease levels in each sub division being estimated as follows: zero disease = 0; less than 25% disease = 1; 25-50% disease = 2; 50-75% disease = 3; 75-100% disease = 4 and 100% disease = 5. The accumulated score per quadrat would be then multiplied by 5 to give an estimate of percentage disease cover per plot.

The severity of diffuse type diseases is assessed either visually on a 1 to 10 scale (1=no disease; 10=severe infection affecting most leaves) or by one of the following methods:

- (a) Using a dropping point quadrat. This is done by scoring the presence or absence of disease on the first leaf touched. A minimum number of 50 but preferably more points (100) should be counted per plot.
- (b) Disease assessment using randomly selected shoots. The severity of the disease is scored by making counts of the presence of the particular disease being assessed on the two youngest fully emerged leaves of randomly selected shoots from each plot. In this case between 10 and 20 shoots should be examined per plot. The total number of disease counts for each leaf examined and the overall total for each plot should be recorded.

**STANDARD OPERATING PROCEDURE NO. 1B0803 (1 page)  
VISUAL ASSESSMENT OF TURF COLOUR**

**[1] Scope**

This standard operating procedure specifies a method for assessing the turf colour.

**[2] Principle**

Turf colour is assessed using a 1 to 10 scale taking into account the depth of colour on the greater part of the turf sward.

**[3] Procedure**

The turf is assessed on a 1 to 10 visual scale where a score of 1 represents brown/bleached turf; 5 represents moderate green colour considered just acceptable and a score of 10 represents a very dark green turf colour, where appropriate ignoring patches due to disease, weeds etc. Two or more observers shall be used, except under unusual circumstances (e.g. external visits with only one observer present) or with written approval by the relevant head of division.

Each sampling area is assessed once by each assessor on each occasion. Where two or more individuals are carrying out the assessment, each should, acting independently, obtain a unique score for each plot.

**[4] Expression of results**

Where two or more individuals carry out the assessment, the mean value for turf colour is calculated for each test area.

**STANDARD OF OPERATING PROCEDURE NO. 301398 (1 page)  
ASSESSMENT CLEANNESS OF CUT**

**[1] Scope**

This standard operating procedure specifies the regulations governing assessment of cleanness of cut.

**[2] Procedure**

Cleanness of cut is scored visually on a 1 = poor to 10 = good (no ragged ends) scale.